



# Product Change Notification

<b>Date Issued :</b>	May 16, 2024	<b>PCN Number :</b>	515164
<b>Reason for Change :</b>	Equipment Transfer, Production Transfer or Rearrangement		
<b>Description of Change :</b>	This notification is to inform you of the following changes		
<b>Reason for Short Notice :</b>	Capacity Increase		
<b>Assessment of Change :</b>	Reliability Test Report/s		
<b>Planned Implementation Date :</b>	August 10, 2024		
<b>Customer Sample Availability Date:</b>	July 15, 2024		
<b>Last date to request Samples by Customer :</b>	June 30, 2024		
Please note if Samples are not requested as per Customer Samples Request date, it may take additional 4-6 weeks to arrange Samples.			
<b>Traceability Code Markings / Date :</b>	No special marking on the product or packaging		

Before Picture

■ Detail See Below

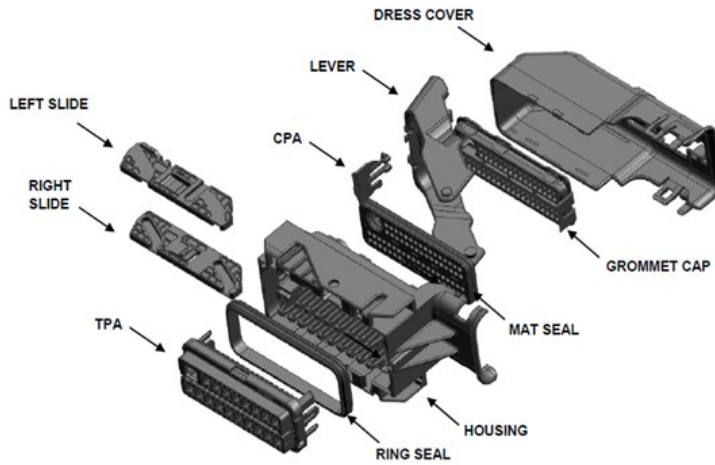

After Picture

## Overview

- The purpose of this letter is to inform you that this PCN related MX123 configurations 66,56 & 18 circuits sizes which are being built in Lincoln facility will be extended to Chengdu to support Asia region. After change, Chengdu capability increase to produce all MX123 configurations from 80,73&49 to 80,73,66,56,49&18. Molex will follow our internal qualification process for PV testing to meet the Specifications.
- The detail change below
  - 1.Tool transfer - Slide components tools from Lincoln to Chengdu
  - 2. Tool capacity increase
    - Housing:
      - currently producing 73/80 way and will increase capability to 66w
      - currently producing 49 way and will increase capability to 56w & 18W
    - TPA
      - currently producing 73/80 way and will increase capability to 66W
      - currently producing 49 way and will increase capability to 56w & 18W
    - CAP
      - currently producing 73/80 way and will increase capability to 66W
      - currently producing 49 way and will increase capability to 56w & 18W
    - Others
      - The remaining components will be shared to use current MP tools in Chengdu, etc Lever, WDC, Ring Seals, Mat seals, CPAs,
    - Asy Lines
      - currently producing Asy line will be added the capability to assembly 18W, 56W & 66W products.
  - 3. Raw material supplier from the same supplier but will be China local supplier factory supply.
- Production procedures& parameters will keep the same with Lincoln.
- Product Impact: no impacts to fit, form, function.
- Part Number Impact: see attached impacted parts list.
- Qualification Reports and samples available upon request after the date July 15<sup>th</sup>, 2024.

# RELEASED

You may address inquires regarding this PCN by clicking on the below link  
[mailto:pcn\\_coordinator@molex.com?subject=PCN\\_Notification:515164](mailto:pcn_coordinator@molex.com?subject=PCN_Notification:515164)  
 or contact your Local Sales Engineer.

Note: While responding, please retain " PCN Notification : **PCN Notification: 515164** " in the e-mail Subject line for faster response.

[Molex, LLC](#)  
 2222 Wellington Court  
 Lisle, IL 60532  
 TEL (800) 786-6539  
[www.molex.com](http://www.molex.com)

<b>PCN No</b>	<b>Part List</b>
515164	345660064
515164	345660603
515164	345661793
515164	345663713
515164	345668813
515164	345669453
515164	345760703
515164	345760803
515164	345761903
515164	345764303
515164	345766003
515164	345766403
515164	345766883
515164	345766933
515164	345766943
515164	345766963
515164	345766993
515164	345767053
515164	345767063
515164	345767133
515164	345767143
515164	345767153
515164	345767173
515164	345767203
515164	345767263
515164	345767293
515164	345767303
515164	345767343
515164	345767453
515164	345767523
515164	345767543
515164	345767573
515164	345767583
515164	345767593
515164	345769333
515164	345769343
515164	345769353
515164	345769413
515164	345769443
515164	345769473
515164	345769483
515164	348220013
515164	348220023
515164	348220033
515164	348220043

515164 348220073  
515164 348220163  
515164 348220193  
515164 348220223  
515164 348220243  
515164 348220253  
515164 348220263  
515164 348220403  
515164 348220413  
515164 348220423  
515164 348220453  
515164 348220473  
515164 348220483  
515164 348220493  
515164 348220503  
515164 348220513  
515164 348220523  
515164 348220533  
515164 348220563  
515164 348220573  
515164 348220583  
515164 348220643  
515164 348220653  
515164 348220713  
515164 348220733  
515164 348220843  
515164 348220853  
515164 348220863  
515164 348220873  
515164 348220943  
515164 348220953  
515164 348510007  
515164 348510008  
515164 348510019  
515164 348510027  
515164 348510028  
515164 348510029  
515164 348510034  
515164 2167410001  
515164 2167410002  
515164 2167410003  
515164 2167410004  
515164 2167410030  
515164 2167410050  
515164 2167410052  
515164 2167410053

515164 2167420001

515164 2167420007

515164 2167450001