

# molex<sup>®</sup>

**PNEUMATIC STRIPPING MACHINE**  
**Operation Manual**  
**Order No. 63817-1800**

## Table of Contents

1	Introduction .....	4
1.1	Product Specification .....	4
1.2	Conformity .....	4
1.3	Dealing with the Operating Instruction.....	5
2	Safety .....	5
2.1	Warning and Safety Precautions in this Operating Instruction .....	5
2.2	Safety Precautions .....	5
2.3	Responsibilities .....	7
2.4	Designed Use .....	7
2.5	Predictable Misuse.....	7
2.6	Hazardous Areas.....	8
3	Shipment.....	8
3.1	Packing.....	8
3.2	Packing Contents .....	8
4	Technical Description .....	9
4.1	Operating Functions .....	9
4.1.1	Front View .....	9
4.1.2	Back View .....	9
4.2	Machine Identification.....	10
4.3	Technical Data.....	10
4.4	Safety Guard.....	10
5	Transport and Installation.....	11
5.1	Transport.....	11
5.2	Installation.....	11
6	Commissioning.....	11
6.1	Connecting to Compressed Air Supply .....	11
6.2	Setup .....	12
6.2.1	Exchange of Knives .....	13
6.2.2	Mounting the Centering Guide .....	13
6.3	Machine Setup Adjustments .....	14
6.3.1	Stripping Length .....	14
6.3.2	Adjustment Screw for Blade Opening.....	14
7	Normal Operation or Production Cycle .....	14
8	Maintenance .....	15
8.1	Maintenance Plan.....	15
8.1.1	Daily Responsibilities as Required .....	15
8.1.2	Every 2 Years .....	15
9	Problem Handling .....	16
10	Removal From Service, Demounting, Disassembly.....	16
11	Storage .....	16
12	Exploded View Drawing, Parts List and Pneumatic Diagram .....	17
12.1	Exploded View Drawing.....	17

Pneumatic Stripping Machine

12.2 Parts List ..... 18  
12.3 Pneumatic Diagram ..... 19  
12.4 Accessories Overview for Reorders ..... 19

# 1 Introduction

## 1.1 Product Specification

The pneumatic stripping machine is a pneumatic cable stripping machine built as a complete table unit. It strips cable Ø of 4-15mm or 6-70mm<sup>2</sup> (AWG 9-2/0).

All other applications of the pneumatic stripping machine are prohibited. For all unauthorized applications of the pneumatic stripping machine, the manufacturer cannot be held liable for any resultant damage or injury.

## 1.2 Conformity



The machine may only be used for the purpose specified in the operating instruction. The manufacturers and suppliers will not be liable for any damages which may result due to the machine being used for a purpose other than that for which it was intended. This is done entirely at the user's own risk.

The pneumatic stripping machine is CE compliant. The original of the following declaration of conformity was supplied together with the operating instruction of the machine.

 <b>Konformitätserklärung</b> gemäß EG-Richtlinie Maschinen 2006/42/EG vom 17.05.2006 <b>Declaration of Conformity</b> according to EC Machinery Directive 2006/42/EG of May 17 <sup>th</sup> , 2006	
Bezeichnung der Maschine Description of the machine	Pneumatisches Abisoliergerät Pneumatic Crimping Machine
Maschinentyp Type of machine	AKM 405
Seriennummer der Maschine Serial number of the machine	Seriennummer eintragen.
Hersteller der Maschine Manufacturer of the machine	WEZAG GmbH Werkzeugfabrik Wittigstr. 8 35260 Stadtlendorf Deutschland/Germany
Zutreffende EU Richtlinien Applicable EU directives	2006/42/EG    Maschinenrichtlinie Machinery Directive
Angewandte harmonisierte Normen Applied harmonized norms	DIN EN ISO 12100; DIN EN ISO 13857; DIN EN 349; DIN EN ISO 13849-1
Wir erklären, dass die oben genannte Maschine in ihrer Konzipierung und Bauart und in der von uns in Verkehr gebrachten Ausführung allen einschlägigen Bestimmungen der Maschinenrichtlinie sowie den weiteren oben aufgeführten Richtlinien entspricht. Die Schutzziele der Niederspannungsrichtlinie wurden gemäß Anhang I, Nr. 1.5.1 der Maschinenrichtlinie eingehalten. Bei Änderungen der Maschine verliert diese Erklärung ihre Gültigkeit.	
We declare that the above mentioned machine, with its design and type of construction, as well as the produced version, meets all relevant regulations of the Machinery Directive as well as the above mentioned harmonized norms. The protective directions of the Low Voltage Directive have been met in accordance with Annex I, Section 1.5.1 of the Machinery Directive. This declaration will lose its validity in case of any modifications.	
 WEZAG GMBH Werkzeugfabrik Wittigstraße 8 35260 Stadtlendorf Deutschland	
Stadtlendorf, 04.08.2016 Ort & Datum/ Place & Date	Mr. K. Battenfeld/Head of Design & Engineering Name & Funktion/Name & Function
Konformitätserklärung_AKM_REV_A	

Figure 1.1

### 1.3 Dealing with the Operating Instruction

The operating instruction contains all information concerning operating elements, operation, commissioning and maintenance work as well as technical data.

The operation instruction must be constantly within reach of the pneumatic stripping machine. Every machine operator must read and understand the operating instruction to ensure safe and efficient production with this piece of equipment.

The producer as well as the distributor decline to accept any liability for damages that are incurred due to the fact that the instructions on the machine or in the operation instruction have been disregarded.

The user is responsible for supplementing the operation instruction with any instructions resulting from current national regulations for accident prevention and protection of the environment.

## 2 Safety

### 2.1 Warning and Safety Precautions in this Operating Instruction

The following warnings and safety-related cautionary notices in the individual chapters alert you to various levels of danger:



---

#### **DANGER**

- Identifies an imminent, serious danger, which, if it is not avoided, will lead to serious injuries or even to death.
- 



---

#### **CAUTION**

- Identifies a possible danger, which, if it is not avoided, will lead to serious injuries or even to death.
- 



---

#### **ATTENTION**

- Identifies a potential dangerous situation, which, if it is not avoided, can lead to medium or minor injuries or material damages.
- 



---

#### **INFORMATION**

- If this information is not followed, it can lead to a deterioration of the operating procedure.
- 

### 2.2 Safety Precautions

When carrying out jobs such as installation, putting the machine into operation or setting it up, operation, changing the conditions of use and the mode of operation or carrying out maintenance and service jobs, it is important to observe the procedures for switching off the machine described in the operation instruction.

Please observe the national regulations according to the minimum age of the personnel operating the pneumatic stripping machine. Allowing younger persons access to the machine is strictly prohibited.

## Pneumatic Stripping Machine

- Do not operate the pneumatic stripping machine until you have studied and fully understood all of the instructions described in this operating instruction.
- Operate the pneumatic stripping machine in a dry and dust-free environment only. The stripping machine is only allowed to be used when it is in completely functional condition.
- Do not modify the pneumatic stripping machine nor use it for any purpose for which it was not intended.
- Position the pneumatic stripping machine on a flat surface and assure the stability of the machine. Ensure that the table or bench is stable enough to support the machine in normal use.
- Assure an appropriate table height. The table height is dependent on the position of the operator (work in sitting or standing position) according to prEN 894-4:2004, Table A.1.
- The pneumatic stripping machine does not have its own light source. Assure appropriate illumination of the workplace (EN 1837:1999 – chapter 4.2: "The general value of illumination has to be 500 lx [...]").
- Connect the compressed air supply with the supplied compressed air tube.
- Place the tubes on the floor so they do not cause a trip hazard.
- Place the foot pedal on the floor. No other place is allowed. The foot pedal must be movable so that the operator has the possibility to change his or her position for ergonomic and production needs.
- Do not lay the foot pedal in aisles or walkways.
- Assure free access to the operating elements of the machine, especially the foot pedal.
- Maintenance work may be performed only by authorized and properly trained personnel.
- The safety guard may only be removed by the installation engineer.
- Due to the risk of hand or finger injury, never try to reach into the stripping unit before having assured that the machine is disconnected from the air supply. Disconnect the air supply before changing the safety guard. The safety guard may only be removed when the machine is not in operation and has been disconnected from the air supply.
- Before commissioning the machine, it is always important to check whether all safety devices—especially the safety guards—are installed and functioning correctly. Safety guards may only be removed when the machine is not in operation and has been disconnected from the air supply.
- Prior to starting up the pneumatic stripping machine, you have to check the condition of the connecting tubes. The tubes must not show any damage. Damages have to be repaired before continuing to work with the machine.
- Prior to starting up the pneumatic stripping machine, make sure it is firmly positioned on a sturdy stand or bench to prevent it from tipping over.
- Exercise caution at all times when the pneumatic stripping machine is switched on.
- The pneumatic stripping machine may only be set up and operated in perfect technical conditions, observing all the safety regulations and considering any possible dangers.
- The pneumatic stripping machine is only allowed to be used when it is in completely functional condition.
- The machine is not allowed to be used without a mounted safety guard.
- If you suspect that the machine cannot be operated safely, it must be switched off and secured against anyone accidentally switching it on.
- In cases of a machine malfunction, production must be stopped and the malfunction must be fixed before continuing work with the machine.
- Work with caution.
- Only one person is allowed to work on or with the machine at a time.
- Only trained personnel are allowed to work on or with the machine.
- The pneumatic stripping machine should only be operated with the specified working pressure.
- When working with the pneumatic stripping machine, do not wear loose clothing, jewelry or long, loose hair that can get caught in the machine.
- The safety guard may only be removed when the pneumatic stripping machine is disconnected from the air supply.

## Pneumatic Stripping Machine

- Disconnect the pneumatic stripping machine from the air supply before attempting any maintenance work. Never reach into the stripping unit before the machine is disconnected from the air supply.
- Use only lubricated and filtered compressed air.
- For maintenance work, wear adequate protective gloves and safety glasses.

### 2.3 Responsibilities

The pneumatic stripping machine may only be operated by suitably trained and authorized personnel. The user must clearly define and observe the responsibilities for operation, setup, maintenance and service. It is particularly important to define who is responsible for work on the pneumatic equipment. Such work should only be carried out by specially trained staff.

Should the user make any changes to the machine without consulting the manufacturers or the suppliers, the latter will not be liable for any damage that may result.

The user of the pneumatic stripping machine is responsible for making sure that all persons involved in any way, either in the installation or in maintenance of the machine, have been thoroughly trained on the system using the this operating instruction.

The user is also responsible for the training of operators, and the instruction must include the following aspects:

- Purpose of the machine
- Hazard zones
- Safety rules and regulations
- Functionality of the various components of the machine
- Proper operation of the machine

To assure full familiarization with the system, the training must be conducted in the native language of the operators involved.

Staff Qualifications Required in Conjunction with the Use of the Pneumatic Stripping Machine	
Installation Setup Instruction	Technical personnel with language proficiency in either English or German in addition to the native language of the operator
Operation	Through qualified personnel trained as indicated above
Maintenance Service	Technical personnel with proficiency in English or German

The safety instructions, warnings and precautions contained in the individual chapters must be strictly observed by all users and operators.

### 2.4 Designed Use

- Stripping of cable Ø 4-15mm or 6-70mm<sup>2</sup> (AWG 9-2/0)

### 2.5 Predictable Misuse

- Every application that is not mentioned in Section 2.4
- Stripping of other cable Ø.

**2.6 Hazardous Areas**

- 1. **Hazardous Area:** Area of interchangeable stripping knives  
**Person at Risk:** Operator  
**Type of Hazard:** Risk of cutting
  
- 2. **Hazardous Area:** Opened machine  
**Person at Risk:** Installation engineer  
**Type of Hazard:** Direct or indirect contact with movable parts of the machine  
 Risk of cutting  
 Risk of crushing

**3 Shipment**

**3.1 Packing**

Please unpack your pneumatic stripping machine carefully and, if possible, retain the original packaging for possible further dispatch and for storage, if required.

**3.2 Packing Contents**

Quantity	Description
1 pc.	Pneumatic stripping machine
1 pc.	Pneumatic foot pedal with safety cover
1 pc.	Triple set of knives with 4 blades per set Ø 4-15mm
6 pcs.	Centering guides Ø 6, 8, 10, 12, 14, 16mm
3 pcs.	Air tubing of 2 meters
1 pc.	Tool set
1 pc.	Operating instruction
1 pc.	Declaration of conformity



## 4 Technical Description

### 4.1 Operating Functions

#### 4.1.1 Front View

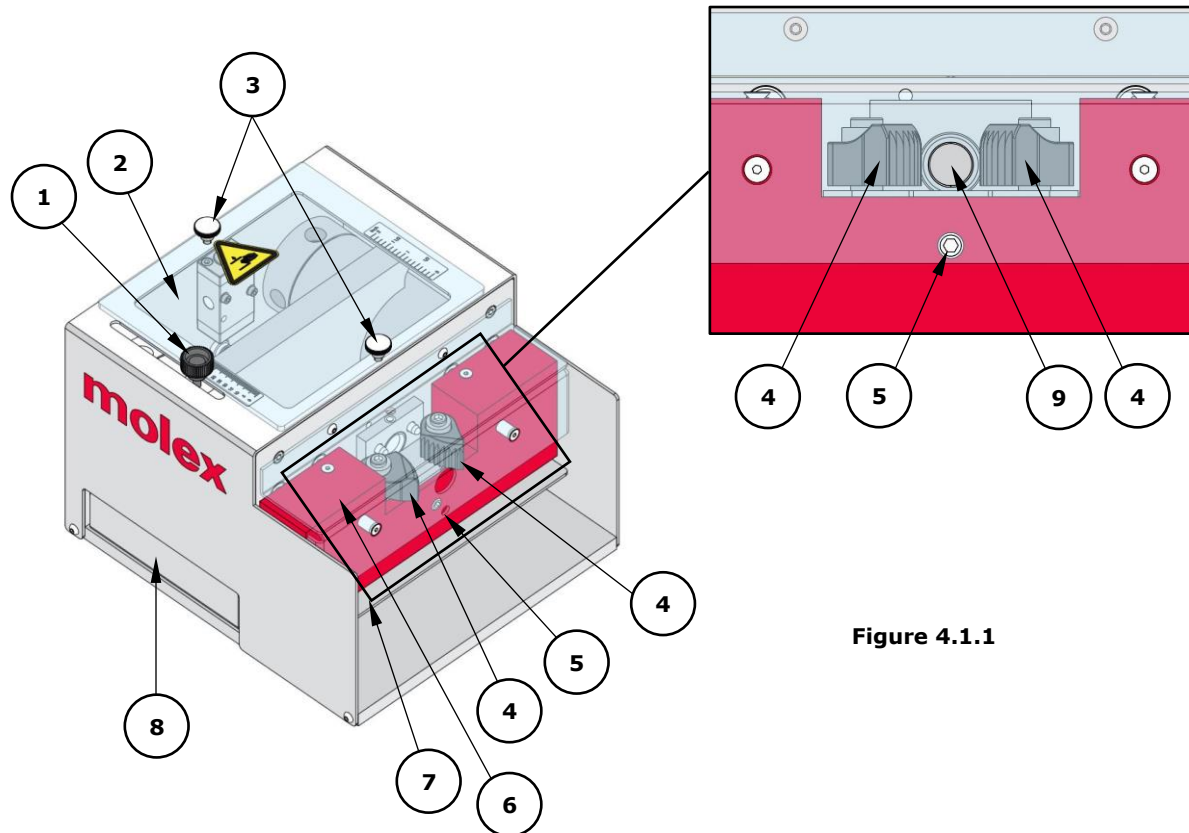

Figure 4.1.1

Item	Description
1	Adjustment screw for stripping length
2	Safety guard
3	Screws for safety guard
4	Cable clamps
5	Adjustment screw for blade opening
6	Upper finger protection
7	Lower finger protection
8	Container for waste
9	Centering guide

#### 4.1.2 Back View

Item	Description
10	Connection 6mm
11	Connection 8mm

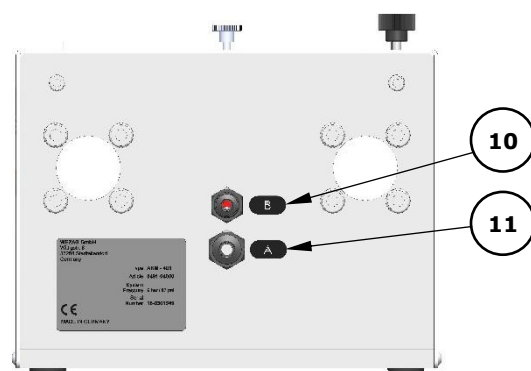

Figure 4.1.2

### 4.2 Machine Identification

Item	Description
12	Machine type
13	Article number
14	System pressure
15	Serial number

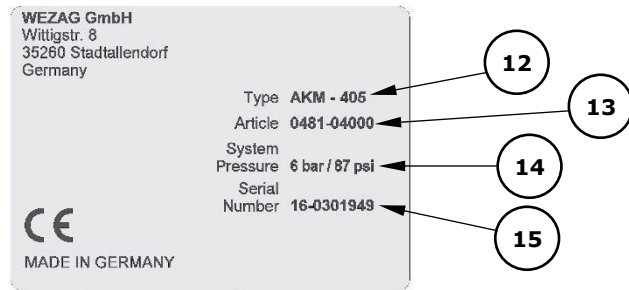

Figure 4.2.1

### 4.3 Technical Data

Description	Specification
Suitable for inner cable diameters	4-15mm (.15-.60")
	6-70mm <sup>2</sup> (9-2/0 AWG)
Strip length	5-50mm (.20-2.0")
	5-85mm (.20-3.3")
Maximum Insulation O/D	16mm
Length	250mm (9.8")
Width	230mm (9.1")
Height	190mm (7.5")
Weight	Approximately 11 kg (24 lbs.)
Air Pressure	Maximum 6 bar (90 psi)

### 4.4 Safety Guard

The pneumatic stripping machine is equipped with a safety guard made of plastic (16). The safety guard is controlled by a pneumatic button. If the safety guard is removed, the machine cannot be operated.

#### DANGER



- The safety guard may only be removed when the pneumatic stripping machine is disconnected from the air supply.
- The safety guard may only be removed by the installation engineer.

#### INFORMATION



- In case of an accident because of mishandling or manipulation of the safety guard, the manufacturer cannot be held liable for any resultant damage or injury.

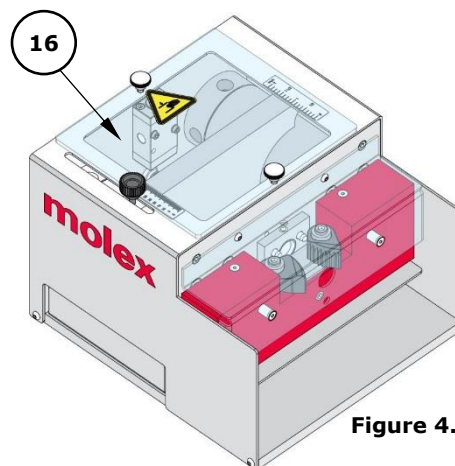

Figure 4.4.1

## 5 Transport and Installation

### 5.1 Transport

The pneumatic stripping machine weighs approximately 24 pounds.

### 5.2 Installation



#### INFORMATION

- To reduce production noise or vibration, the machine can be placed on an insulating rubber mat.
- 



#### ATTENTION

- Position the pneumatic stripping machine on a flat surface and assure the stability of the machine. Ensure that the table or bench is stable enough to support the machine in normal use.
  - Assure an appropriate table height. The table height is dependent on the position of the operator (work in sitting or standing position) according to prEN 894-4:2004, Table A.1.
  - The pneumatic stripping machine does not have its own light source. Assure appropriate illumination of the workplace (EN 1837:1999 – chapter 4.2: "The general value of illumination has to be 500 lx [...]").
- 

Place the foot pedal on the floor. No other place is allowed.

---



#### INFORAMTION

- When the operator is positioned in front of the machine, the pedal should be placed in a comfortable position. The pedal should be placed on an anti-slip rubber mat. The foot pedal must be movable so that the operator has the possibility to change his or her position for ergonomic and production needs.
- 



#### ATTENTION

- Place the tubes on the floor so that they do not cause a trip hazard.
  - Do not lay the foot pedal in aisles or walkways.
  - Assure free access to the operating elements of the machine, especially the foot pedal.
- 

## 6 Commissioning

### 6.1 Connecting to Compressed Air Supply



#### DANGER

Due to the risk of hand or finger injury, never try to reach into the stripping unit before having assured that the machine is disconnected from the air supply. Disconnect the air supply before changing the safety guard.

---



**CAUTION**

- The pneumatic stripping machine may only be set up and operated in perfect technical conditions, observing all the safety regulations and considering any possible dangers.
- Before commissioning the machine, it is always important to check whether all safety devices, especially the safety guards are installed and are functioning correctly. Safety guards may only be removed when the machine is not in operation and has been disconnected from the air supply.
- The pneumatic stripping machine is only allowed to be used when it is in completely functional condition.
- When working with the pneumatic stripping machine, do not wear loose clothing, jewelry or long, loose hair that can get caught in the pneumatic stripping machine.
- Work with caution.
- In cases of a machine malfunction, production must be stopped, and the malfunction must be fixed before continuing work with the machine.
- Only one person is allowed to work on or with the machine at a time.
- Only trained personnel are allowed to work on or with the machine.
- Only use the pneumatic stripping machine with the specified working pressure.

Use the pneumatic stripping machine only with conditioned air (lubricated and filtered).

**Standard filter:** 30 µm.

Connect hose stem **(1)** of the pneumatic foot pedal to the compressed air supply. See Figure 6.1.1.

**Air pressure:** 6 bar / 90 psi

Connect hose stem **(2)** of the pneumatic foot pedal to the 6mm connection of the machine **(B)**.

Connect hose stem **(4)** of the pneumatic pedal to the 8mm connection of the machine **(A)**.

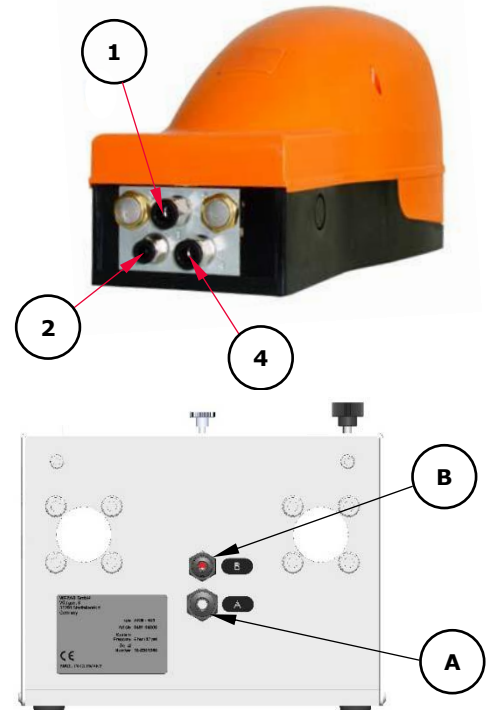

Figure 6.1.1



**CAUTION**

- The machine can only be depressurized by disconnecting the machine from the main air supply **(1)**.
- Connect the compressed air supply with the supplied compressed air tube.



**INFORMATION**

- Use only lubricated and filtered compressed air.

**6.2 Setup**

**DANGER**



- Due to the risk of hand or finger injury, never try to reach into the stripping unit before having assured that the machine is disconnected from the air supply. Disconnect the air supply before changing the safety guard. Safety guard may only be removed when the machine is not in operation and has been disconnected from the air supply.

### 6.2.1 Exchange of Knives

To exchange the knives, proceed as follows (See Figures 6.2.1 and 6.2.2):

- Disconnect the machine from the pneumatic air supply.
- Unscrew the two knurled head screws (1) and remove the safety guard.
- Open the screw (2) of the knife holder.
- Take out the knife holder.
- Choose the correct knife that corresponds to the cable.
- Insert and position the knife.
- Tighten the screws of the knife (3).

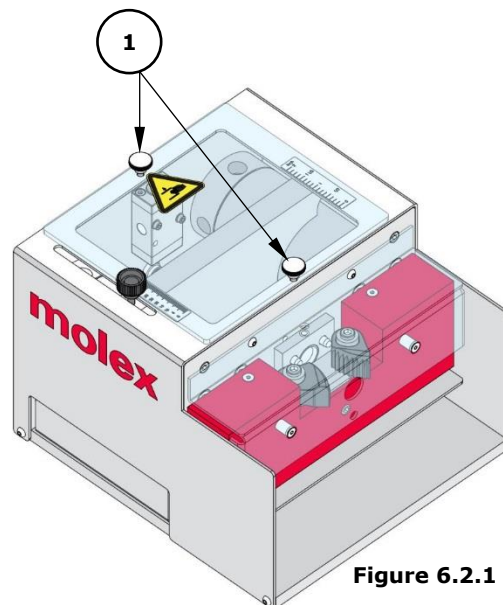

Figure 6.2.1



#### INFORMATION

- By tightening or loosening the four screws (2) at the side of the knife holder, the knives can be adjusted 0.5mm per knife to the center.
- Reinsert the knife holder and tighten screw (2).
- Mount the safety guard and tighten the knurled head screws (1).

### 6.2.2 Mounting the Centering Guide

To mount the centering guide, please proceed as follows (See Figures 6.2.3 and 6.2.4):

- Disconnect the machine from the pneumatic air supply.
- Unscrew the two knurled head screws (1), and remove the safety guard.
- Open the screw (2) of the knife holder.
- Take out the knife holder.
- Open the locking screw (2) of the centering guide.
- Choose the correct centering guide.
- Pull out the centering guide (3) inwardly.
- Mount the new centering guide (3).
- Tighten it lightly with the locking screw (2).
- Mount the safety guard, and tighten the screws (1).

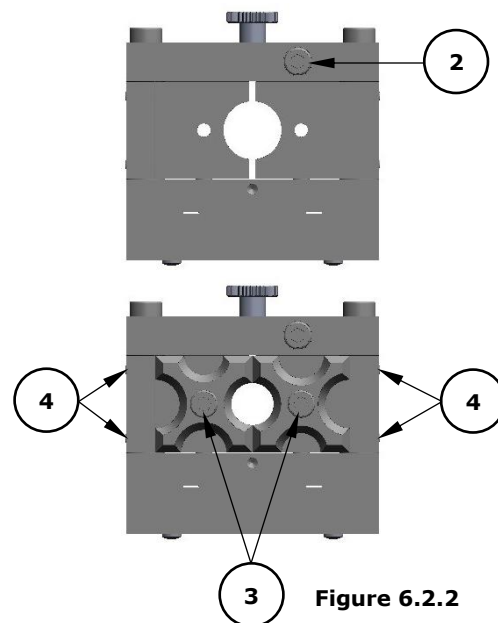

Figure 6.2.2

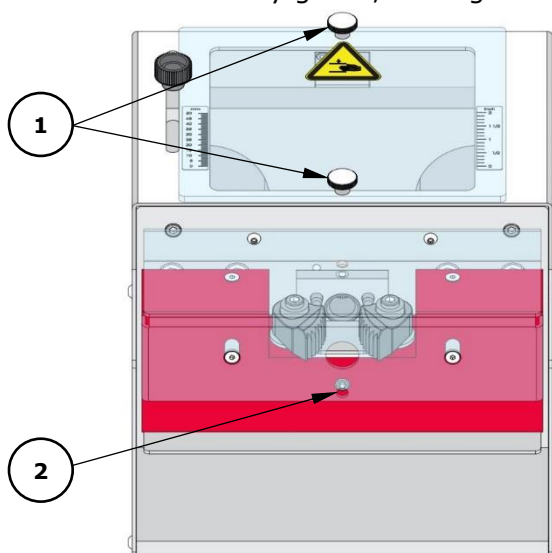

Figure 6.2.3

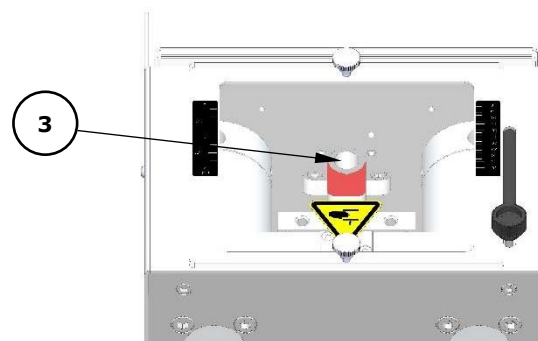

Figure 6.2.4

## 6.3 Machine Setup Adjustments

### 6.3.1 Stripping Length

To set the stripping length, proceed as follows (See Figure 6.3.1):

- Loosen the adjustment screw for the stripping length (4).
- Adjust the required stripping length by sliding it to the correct position.
- Tighten the adjustment screw (4).

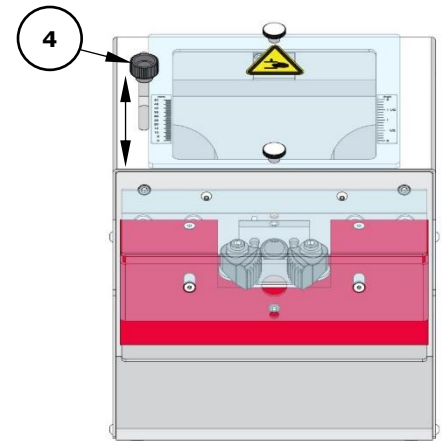

Figure 6.3.1

### 6.3.2 Adjustment Screw for Blade Opening

Adjust the hex screw (1) with the 4mm hex key until the blade opening matches the outside diameter of the cable to be processed. See Figure 6.3.2.

- Turning the screw clockwise enlarges the opening of the blades.
- Turning the screw counterclockwise makes it smaller.

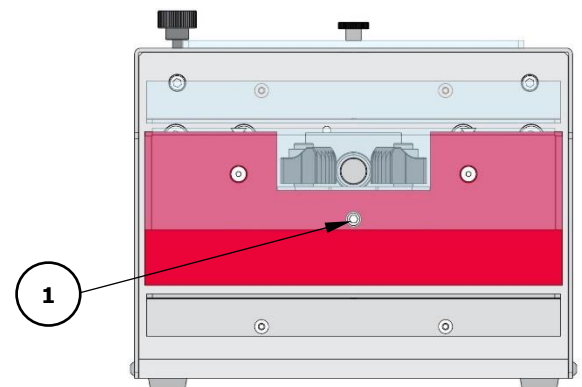

Figure 6.3.2

## 7 Normal Operation or Production Cycle



### ATTENTION

- Prior to starting up the pneumatic stripping machine, make sure it is firmly positioned on a sturdy stand or bench to prevent it from tipping over.
- Assure an appropriate table height. The table height is dependent on the position of the operator (work in sitting or standing position) according to prEN 894-4:2004, Table A.1.
- The pneumatic stripping machine does not have its own light source. Assure an appropriate illumination of the workplace (EN 1837:1999 – chapter 4.2: "The general value of illumination has to be 500 lx [...]").
- Prior to starting up the pneumatic stripping machine, you have to check the condition of the connecting tubes. The tubes must not show any damage. Damages have to be repaired before continuing to work with the machine.
- The machine is only allowed to be used when it is in completely functional condition.
- Place the tubes on the floor so that they do not cause a trip hazard.
- Place the foot pedal on the floor only. Do not lay the foot pedal in aisles or walkways.



### CAUTION

- When working with the pneumatic stripping machine, do not wear loose clothing, jewelry or long, loose hair that can get caught in the pneumatic stripping machine.

- Choose the required stripping length with the adjustment screw.
- Mount the suitable knife (4-15mm) and centering guide.
- Push the cable between the cable clamps through the centering guide until it stops.
- Keep hold of the cable.
- Press the pneumatic foot pedal to start the stripping process.
- Pull out the cable.

## 8 Maintenance



---

### DANGER

- Due to the risk of hand or finger injury, never try to reach into the stripping unit before having assured that the machine is disconnected from the air supply. Disconnect the air supply before changing the safety guard. The safety guard may only be removed when the machine is not in operation and has been disconnected from the air supply.
- 



---

### CAUTION

- When working with the pneumatic stripping machine, do not wear loose clothing, jewelry or long, loose hair that can get caught in the machine.
  - Maintenance work may be performed only by authorized and properly trained personnel.
- 

### 8.1 Maintenance Plan



---

### DANGER

Disconnect the air supply before changing the safety guard. The safety guard may only be removed when the machine is not in operation and has been disconnected from the air supply.

---

Regular maintenance and cleaning of the parts that can be reached without opening the machine will prolong the life of the machine. Do not use rough materials to clean the machine such as wire wool. The machine or machine parts should not be cleaned with compressed air. The machine and machine parts must not be cleaned with hard objects like scrapers, steel wool or similar products. Vacuum heavily soiled parts.

#### 8.1.1 Daily Responsibilities as Required

- Visual control
- Check air pressure 6 bar / 90 psi
- Remove waste
- Clean the machine from the talc

#### 8.1.2 Every 2 Years

Please contact the producer or distributor of the machine for inspections in the recommended intervals.

## 9 Problem Handling



### DANGER

- Due to the risk of hand or finger injury, never try to reach into the stripping unit before having assured that the machine is disconnected from the air supply. Disconnect the air supply before changing the safety guard. The safety guard may only be removed when the machine is not in operation and has been disconnected from the air supply.



### CAUTION

- When working with the pneumatic stripping machine, do not wear loose clothing, jewelry or long, loose hair that can get caught in the machine.
- Maintenance work may be performed only by authorized and properly trained personnel.



### ATTENTION

- Prior to starting up the pneumatic stripping machine, you have to check the condition of the connecting tubes. The tubes must not show any damage. Damages have to be repaired before continuing to work with the machine.

In the event of a problem, Molex service department personnel will be able to help you. Therefore, please send the tool to the following address:

Molex Application Tooling  
3 Sammons Court  
Bolingbrook, IL 60440

**Telephone:** (402) 458-TOOL (8665)

Please have the following information ready when you contact service:

- Tool type
- Tool serial number

## 10 Removal From Service, Demounting, Disassembly



### DANGER

- Due to the risk of hand or finger injury, never try to reach into the stripping unit before having assured that the machine is disconnected from the air supply. Disconnect the air supply before changing the safety guard. The safety guard may only be removed when the machine is not in operation and has been disconnected from the air supply.



### CAUTION

- When working with the pneumatic stripping machine, do not wear loose clothing, jewelry or long, loose hair that can get caught in the machine.
- Maintenance work may be performed only by authorized and properly trained personnel.
- The pneumatic stripping machine can only be removed from service with mounted safety guards.

## 11 Storage

Store the machine in the original box at room temperature.



## 12 Exploded View Drawing, Parts List and Pneumatic Diagram

### 12.1 Exploded View Drawing

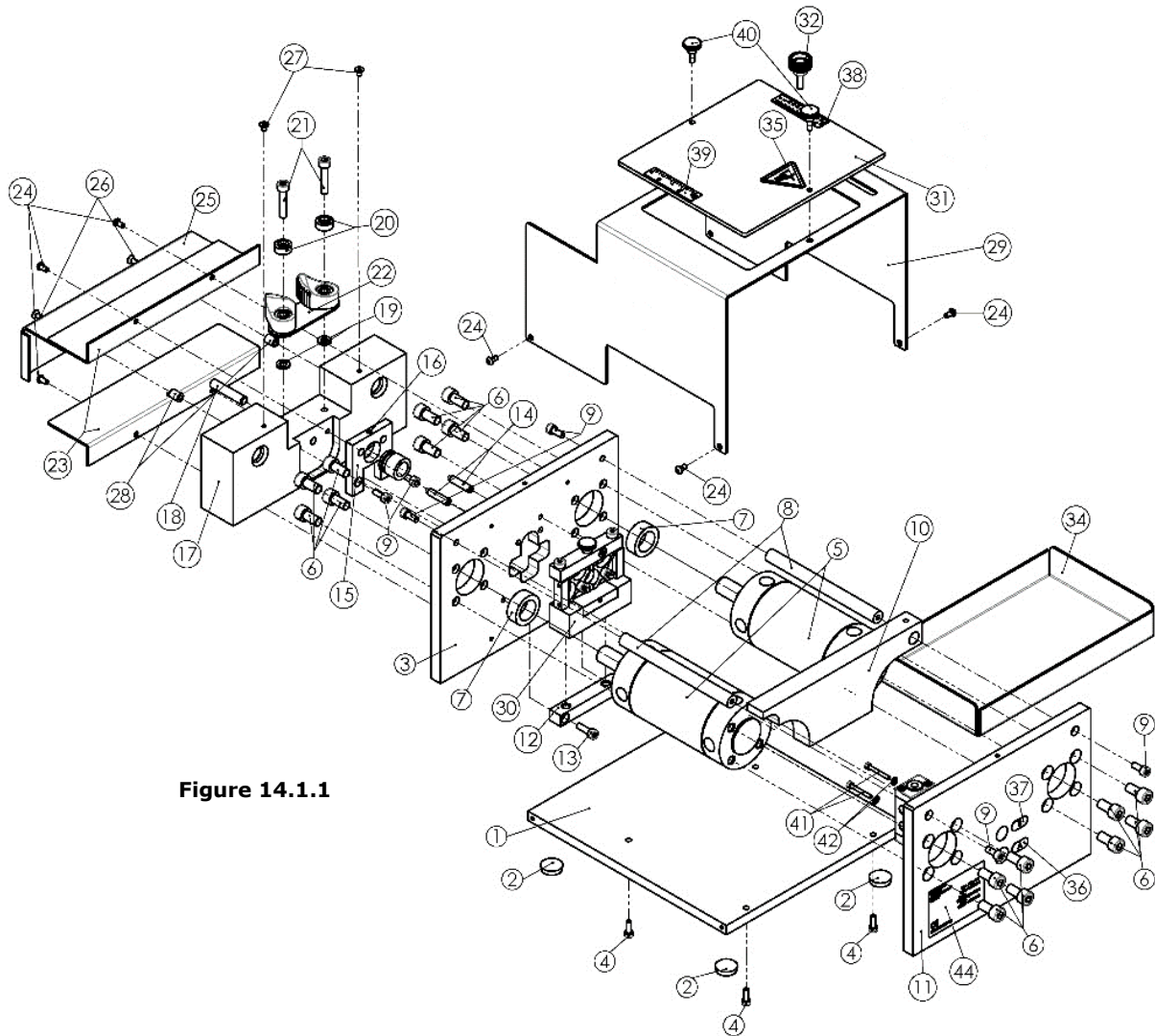
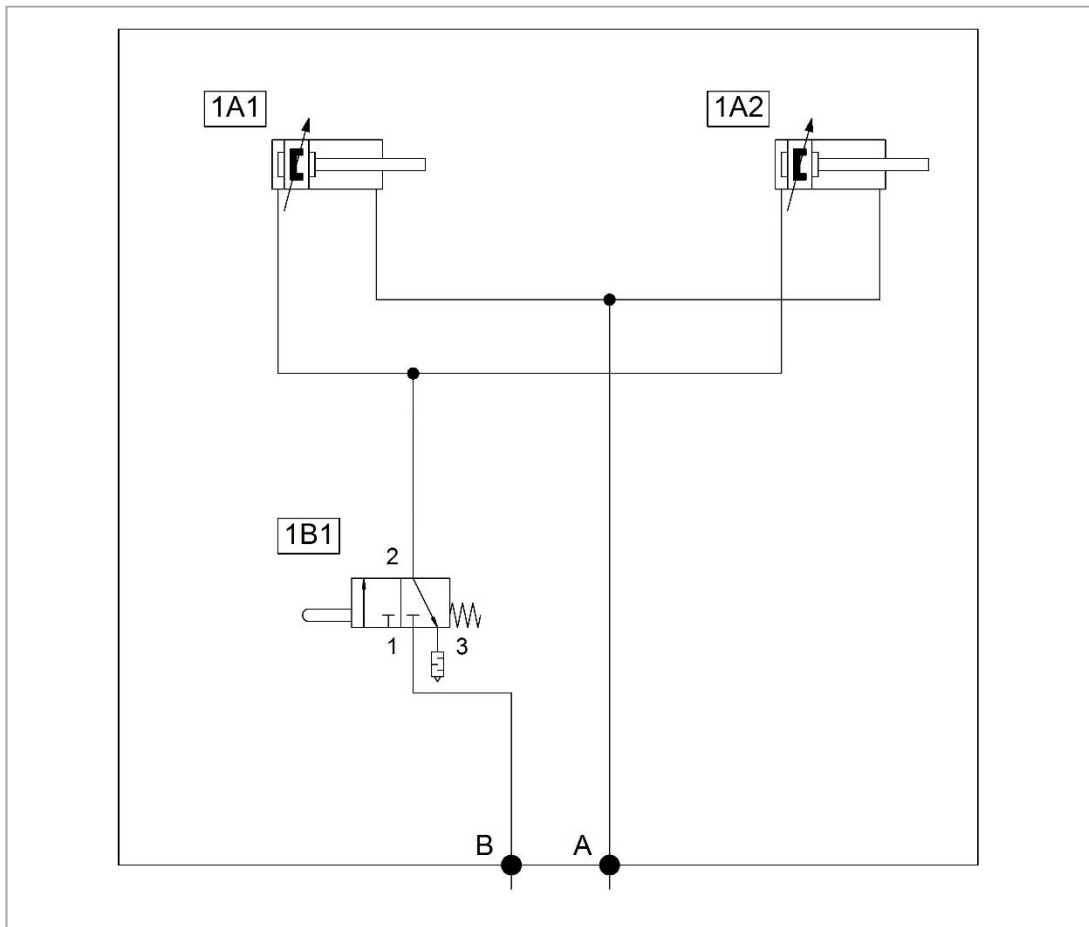

Figure 14.1.1

**12.2 Parts List**

Number	Quantity	Order Number	Description
1	1		Bottom plate
2	4		Rubber foot Ø20
3	1		Front
4	4		Hex. socket screw M4x12 DIN912
5	2		Pneumatic cylinder Ø63/20x50
6	16		Hex. socket screw M8x16 DIN912
7	2		Buffer-1296-29
8	2		Stop bar
9	6		Hex. socket screw M5x12 DIN912
10	1		Stop plate
11	1		Rear panel
12	1		Aligning support
13	2		Hex. socket screw M5x16 DIN912
14	2		Special set screw
15	1		Centering guide plate
16	1		Hex. socket set screw M5x10 DIN914
17	1		Tie beam
18	1		Hex. socket set screw M 8x40 DIN913
19	2		Disk A6,4 DIN 125-St
20	2		Special U-disk
21	2		Hex. socket screw M6x30 DIN912
22	1		Schot clip Servo 44
23	2		Covering plate 1
24	8		Hex. lens head screw M4x8
25	1	63817-1809	Front Guard (Covering plate 4)
26	2		Hex. Socket countersunk head screw M4x16 DIN7991
27	2		Hex. Socket countersunk head screw M4x6 DIN7991
28	2		Distance plate
29	1		Cover
30	1		Knife unit
31	1	63817-1808	Top Guard (Covering plate 3)
32	1		Knurled head screw 2720-95-M5x18-GS
33	1		Pneumatic complete
34	1		Drawer
35	1		Label "Warnung vor Handverletzungen"
36	1		Label A
37	1		Label B
38	1		Scale Stripping length mm
39	1		Scale Stripping length inch
40	2		Knurled head screw M4x12 DIN 464
41	2		Hex. socket screw M3x25 DIN912
42	2		Disc A3,2 DIN125-ST galvanized
44	1		Machine Identification

### 12.3 Pneumatic Diagram



ID	Pieces	Order Number	Description
1B1	1	63817-1801	3-Port/2-Way Air Valve
1A1, 1A2	2	63817-1802	Double Acting Air Cylinder

### 12.4 Accessories Overview for Reorders

Description	Order Number
Centering Guide Set	63817-1803
Knife Set	63817-1804
Hex Wrench Set	63817-1805
Air Hose Set	63817-1806
Pneumatic Food Pedal	63817-1807

#### Application Tooling Support

**Phone:** (402) 458-TOOL (8665)

**E-Mail:** [applicationtooling@molex.com](mailto:applicationtooling@molex.com)

**Website:** [www.molex.com/applicationtooling](http://www.molex.com/applicationtooling)

Molex is a registered trademark of Molex, LLC in the United States of America and may be registered in other countries; all other trademarks listed herein belong to their respective owners.